

Glasswashers

Elegance and simplicity



Useful Innovation

The Benefits



Versatility

The bar world has undergone profound changes, from bars essentially serving coffees and drinks today they have become multi-purpose meeting places, where depending on the time of day they serve a wide variety of food and drinks, from coffee and cakes in the morning to complete meals with quality wines and sophisticated cocktails in the evening.

Glass washers must be able to match this continuous evolution step by step, without however increasing in size, as space is certainly the scarcest and most precious resource inside the bar.

The new generation of Colged glass washers offers an effective solution to this problem: despite the compact external dimensions which can be adapted to any bar counter compartment, the door opening height means that glasses and plates measuring up to 30 cm can be stacked and washed.

As there are many different types of commercial business, the Colged range is structured into different families of machines of increasing capacity and different mixes of rack size and door opening height, intended for different uses: from the small cup/glass washer with 35 rack to versatile machines with 40 cm racks up to larger machines with 45 or 50 cm racks, which can also be used as cutlery washers.

The table demonstrates all this variety at a glance, and can help you to select the most suitable type of product for your needs.

Special bar - double rack

Breakfast at the bar, with coffee or cappuccino, is a ritual that few people are willing to miss out on.

This means that early in the morning there is a lot of work, creating authentic mountains of cups, saucers and spoons piled up in the rack; this frequently leads to breakages, and often washes that are not 100% perfect.

Washing lots of items in a short time is not the right answer.

Colged proposes a rational way of washing large quantities in a short time: the removable double rack.

With its extra-large door opening height 32 cm, all glass washers with 40 x 40 cm rack can be equipped with an optional support for washing two racks at the same time.

The lower rack is used to wash cups with max. height 12,5 cm, and the upper rack saucers with a diameter up to 15,5 cm and spoons.

This means that productivity remains high, but the items are stacked tidily to avoid overlapping and unwanted contact.

Once the breakfast rush-hour is over, the double rack device can be removed in just a few seconds, without taking up any additional space, and the glass washer is instantly ready for washing cocktail glasses and plates with up to 30 cm diameter, for the aperitif hour or lunchtime.

MODEL	Rack size cm	Glass max. height cm	Plate max. height cm	Upper wash	Double rack option	Water softener version
serie 33	35 x 35	25	n.a.	no	no	yes
serie 34	39 x 39 40 x 40	30	30	yes	yes	yes
serie 35-0	45 x 45	28	28	yes	no	yes
serie 35-2	50 x 50	26	27	yes	no	yes



Operational flexibility

Space is a valuable resource in any bar and this is why Colged has created truly multifunctional dishwashers that are able to fulfil a variety of very different functions as the need arises.

All our glasswashers machines have three standard programmes for glasses, up to three programmes for self-cleaning and tank water changing and up to four specialised programmes.

Standard programmes

Differ not only for their contact time (cycle duration), but also for their wash and rinse temperatures and water consumption. Each programme is designed for a specific purpose: **ProSpeed**: for fresh, light soiling; **ProFessional**: for general use; **ProTemp**: with high temperature water rinse.

Specialised programmes

Transform the glasswasher into a real dishwasher, into a cutlery washer and into a machine suitable for osmosis device system.

ProCold: with two rinses, the first with hot water and the second with cold water; **ProPlates**: for plates; **ProWater**: specially for osmosis water; **ProSteel**: for steel cutlery.



Easy cleaning

Colged dishwashers are constructed in accordance with the **TotalClean** design philosophy to make end-of-shift cleaning operations as quick and easy as possible. This entails a number of important design features:

Construction

No pipes inside the wash chambers, deep-drawn rack guides with no blind spots where dirt can accumulate, unblockable integral surface strainers, with 2.5 mm diameter mesh and dished to trap dirt during emptying.

Functionality

Progressive triple-stage filtration of the tank water with elimination of particles down to a diameter of 0.8 mm; programme for self-cleaning of the wash chamber; wash arms with the **EasyHandling** system, which means they can be removed simply by pressing a button and then clicked back into place.

Self-clean programmes

These programmes simplify and speed-up end-of-shift operations and allow rapid changeover of all the water contained in the wash tank. Depending on the model and the version, the machine may offer up to three programmes of this type.

ProSelf: self-clean cycle for machines with gravity draining; **ProNew**: total water change; **ProClean**: self-clean cycle with high-pressure jets for machines with **EvoLution** draining; **ProDrain**: automatic tank draining.



PROGRAMME	MAIN USE	Duration min. sec.	Washing °C *	Rinsing °C *	Consump min. lt/cycle*
ProSpeed	Light, fresh soiling	90	60	65	1,5 - 2,0
ProFessional	General use	120	60	65	1,5 - 2,0
ProTemp	Heavy soiling - high temperature cycle	150	60	80	1,8 - 2,5
ProWater	Glass and crystal with osmosis-treated water	120	65	75	1,5 - 2,0
ProPlates	For plates	150	60	80	1,8 - 2,5
ProCold	Second rinse with cold water	180	60	65 + cold	1,8 + 1,8
ProLong	Heavy soiling - continuous wash	600	60	80	2,5
ProNew	Rapid water changeover	540	n.a.	60	8,0 - 15,0
ProSteel	Cutlery	360	72	88	2,5
ProSelf	Self-cleaning	120	n.a.	n.a.	2,0 - 3,5
ProClean	Self-cleaning and automatic draining	300	n.a.	n.a.	8,0 - 15,0
ProDrain	Automatic draining	90 - 120	n.a.	n.a.	n.a.

* Depending on model and version

The Technologies

Water distribution system

The main component is the **HiTech** arm made from a composite material called **ProComposit** (30% fibreglass, 30% talcum microparticles, 40% organic resin). During rinsing, patented **UltraRinse** geometry ensures that the water is used more effectively and efficiently, thereby helping to minimise consumption.

The washing nozzles are on the same level as the rinse nozzles; this means that the spray is not obstructed, as is the case with the normal arrangement of separate wash and rinse arms. The arm rotates on 3 graphite bearings which reduce friction to virtually zero; this means the full force of the water from the pump is applied to wash the dishes rather than to rotate the arm via the reaction holes.

The **HiTech** arm features a snap-fit attachment system, which makes it easy to install and remove for cleaning, even with just one hand. Its mechanical strength, elasticity, resistance to chemical attack and simplicity of cleaning make this component particularly effective.

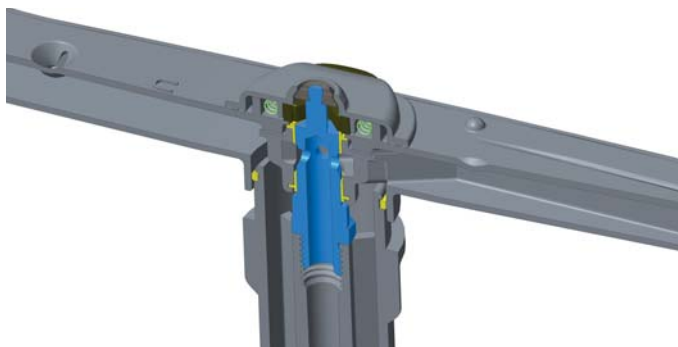

Washing system

The heart of the system is the powerful pump with patented **DuoFlo** technology. Thanks to the pump's two outlets, with one outlet connected directly to the upper arm and the other to the lower arm, this system eliminates the loss of pressure caused by dividing the flow; in this way all the energy absorbed is transferred to the water, thereby achieving an effect equivalent to an enhanced conventional pump. This means the same performance is achieved as competitors' products but with an energy saving of 25%.

A shorter wash cycle, with lower water and detergent consumption, is possible only with a higher wash temperature. Unfortunately, the majority of products on the market have tank and boiler heating elements that function alternately, with priority given to the boiler for reasons of hygiene. This means that, with repeated cycles, the tank is not heated sufficiently and its temperature falls rapidly, thereby compromising washing results. On the new Colged dishwashers, the **HotWash** system instead shares the electrical power between two independent heating elements so as to allow numerous repeated wash cycles and constant heating of the tank. The result, compared with a machine with interlocked heating elements, is that the temperature is around 10 degrees higher during repeated wash cycles: this allows a shorter wash time and a shorter drying time as the plates get hotter, lower detergent consumption and consequently lower costs.

With the **ProDose** system, detergent products are dosed by an electronically-controlled peristaltic pump, which can be easily adjusted from the control panel, and which ensures constant, precise dosing of detergent and rinse aid without any wastage. On request, the machine may be equipped special level sensors that signal via a message on the display when the detergent tanks need to be changed, thereby avoiding the risk of the dosing units being damaged by running empty.



Rinsing systems

Colged dishwashers employ a number of different rinsing systems, with different levels of complexity and performance, each of which however is capable of ensuring that certain parameters remain constant:

Timed rinse: uses **ThermoStop** to ensure a constant temperature at the start of the rinse cycle; the duration of the cycle is fixed, while the water consumption level depends greatly on the pressure of the mains water supply. It is used on the models 00 - 10 - 20.

The minimum water consumption is 1,5 litres/cycle.

Volumetric rinse: uses **ThermoStop** to ensure a constant temperature at the start of the rinse cycle; the duration of the cycle is variable and depends greatly on the pressure of the mains water supply; the average water consumption is constant and independent of the supply pressure. It is used on the models 01 - 11 - 21.

The minimum water consumption is 1,5 litres/cycle.

ProRinse: ensures that the initial and average rinse temperatures, the flow rate, the pressure and the duration all remain constant. All the physical parameters that determine optimal rinsing are controlled and managed, and this why it is possible to get consumption down as low as 1.5 litres/cycle and achieve constant results, regardless of the characteristics of the water supply. The water is supplied via a beak tank, which conforms to WRAS anti-pollution standards, a non-pressurized boiler and a rinse water suction pump. It is used on the models 12 - 13 - 22 - 23.

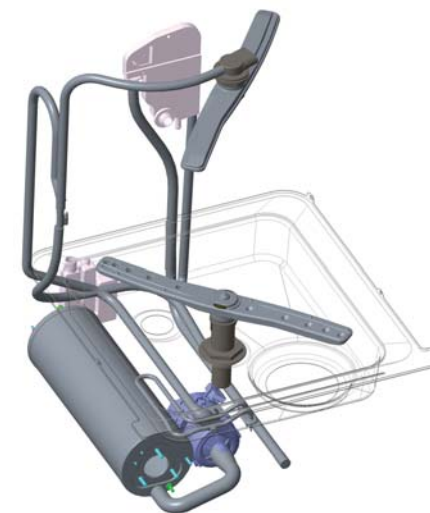

Filtration systems

Colged dishwashers are equipped with two systems for filtration and drainage of the wash waster with different degrees of complexity:

ArchiMedes - A patented system that exploits the principle of communicating vessels to ensure that the dirtiest water at the bottom of the tank is the first to be drained under the pressure of the cleaner water above. This simple but effective device raises the efficiency of the water changeover from the 66% generally obtained with a conventional overflow drain, to 83%; the result is cleaner water in the tank, with the possibility to reduce the amount of water used in the rinse cycle and the concentration of detergent used.

It is used on the models 00 -10 -20 -22 .

EvoLution₃ - A complete and effective system which uses 3-stage water filtration with progressively decreasing mesh size down to 0.8 mm. The water is drained from the bottom of the tank by a specific pump and drainage takes place after washing and before the start of the rinse cycle. This makes for a 100% efficient water changeover and maximum cleanliness of the water in the tank. It is used on the models 01 -11 -13 -20 -23.

In both systems surface filters are used (either in steel or composite material depending on the model) that extend the full width of the tank and are therefore virtually unblockable. We can therefore do without the filter presence sensors or clogging sensors used on many of our competitors' models as they serve no purpose.

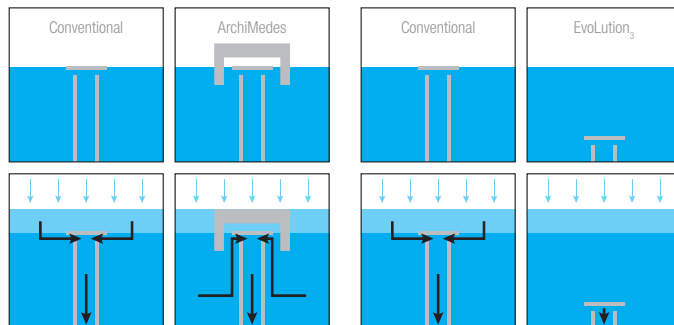

- a) Overflow: water change equal to 62% of the rinse.
- b) ArchiMedes: water change equal to 83% of the rinse.
- c) Evolution₃: water change equal to 100% of the rinse.

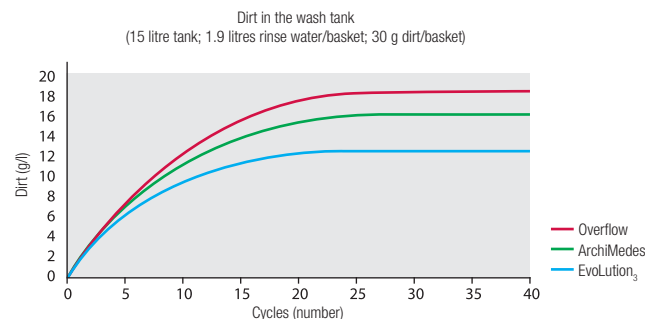

Water treatment systems

Depending on the model, the dishwashers may be equipped with a conventional built-in water softener or with the **CareFree** continuous water softener. With the former type, the user has to stop work and manually start resin regeneration after certain number of wash cycles, which depends on the characteristic of the water supply. The continuous water softener instead automatically performs regeneration during every wash cycle; the only action required of the operator is to top up the salt when requested by a message displayed on the screen of the user interface.

In addition to built-in systems, Colged also offers large-capacity external water softeners, in both manual and automatic versions, decarbonation systems and reverse osmosis filtration system to obtain water that is perfectly purified; osmosis water is especially recommended for washing crystal glasses and cutlery, but has no advantages for washing dishes.

The TopTech range

The top models in the Colged range are extremely technically advanced, with an excellent build quality and feature innovative technologies to offer the very best in terms of productivity, low consumption figures and easy operation. Operational flexibility is also of the highest level, thanks to a wide range of programmes, with, depending on the version, up to three standard programmes and eight specialised programmes, all of which can be easily selected from the direct access menu.

Construction

Full double-skin construction with counterbalanced and thermally insulated full double-skin door. The tank is entirely press-moulded and equipped with a full-width integral surface filter, which, thanks to its large intake size, is virtually unblockable. The wash chamber is free of internal pipes and sharp corners.

User interface

Easy to use, reliable and complete, with four soft touch keys and a large backlit polychromatic LCD display.

Unlike other dishwashers on the market, it is not just a button; the entire screen changes colour according to the operating status of the machine and the current

stage of the wash cycle; this makes the screen easy to read and interpret even from a distance. In addition to the operating parameters, such as the temperature of the tank and boiler or the number of cycles completed, the indications provided by the automatic diagnosis system are also displayed. Information is provided in the form of clear text and icons. It is possible to adjust the tank and boiler temperatures, the dosing of detergent and rinse aid, while our specialised technicians can modify all the operating parameters of the machine.

The versions

Versions with four different equipment levels are available, with and without water softener. The entire range and the various options can be seen in the table on the next page.

All versions are equipped as standard with electronically-controlled peristaltic dosing units for both detergent and rinse aid.

Standard equipment

The glasswashers are equipped with two flat rack, a cutlery container, approved filler hose and drain hose.

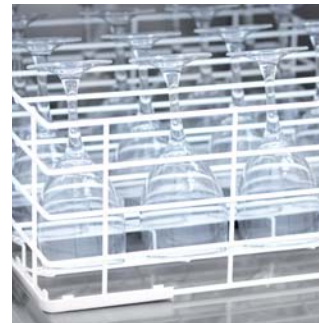

PROGRAMME SELECTION	34-20 D	34-21 D	34-22 D	34-23 D	34-23 TD	35-20 D	35-21 D	35-22 D	35-23 D	35-23 TD
ProSpeed programme	•	•	•	•	•	•	•	•	•	•
ProFessional programme	•	•	•	•	•	•	•	•	•	•
ProTemp programme	•	•	•	•	•	•	•	•	•	•
ProWater programme	•	•	•	•	•	•	•	•	•	•
ProPlates programme	•	•	•	•	•	•	•	•	•	•
ProCold programme				•	•					
ProLong programme						•	•	•	•	•
ProNew programme				•	•		•		•	•
ProSteel programme									•	•
ProSelf self-clean programme	•		•			•		•		
ProClean self-clean programme and automatic drain		•		•	•		•		•	•
ProDrain automatic drain		•		•	•		•			

TECHNOLOGIES	34-20 D	34 -21 D	34-22 D	34-23 D	34-23-TD	35-20 D	35-21 D	35-22 D	35-23 D	35-23 TD
DuoFlow pump	•	•	•	•	•	•	•	•	•	•
HiTech wash arms	•	•	•	•	•	•	•	•	•	•
UltraRinse rinse arm	•	•	•	•	•	•	•	•	•	•
QuickReady rapid tank heating system			•	•	•			•	•	•
EnergySaving system	•	•	•	•	•	•	•	•	•	•
SmartClean construction	•	•	•	•	•	•	•	•	•	•
HotWash heating system	•	•	•	•	•	•	•	•	•	•
ThermoStop rinse control	•	•	•	•	•	•	•	•	•	•
SmartScreen user interface	•	•	•	•	•	•	•	•	•	•
ProRinse system			•	•	•			•	•	•
ArchiMedes drain system	•		•			•		•		
EvoLution₃ drain system		•		•	•		•		•	•
ProGressive triple-stage filtration system		•		•	•		•		•	•
ProDose detergent control system	•	•	•	•	•	•	•	•	•	•
CareFree automatic water softener					•					•

CHARACTERISTICS

Rack dimension	cm	40 x 40	40 x 40	40 x 40	40 x 40	40 x 40	50 x 50	50 x 50	50 x 50	50 x 50	50 x 50
Distance between guides	cm	40	40	40	40	40	50	50	50	50	50
Full double-skin construction		•	•	•	•	•	•	•	•	•	•
Deep-drawn rack guides		•	•	•	•	•	•	•	•	•	•
Tank with press-moulded bottom		•	•	•	•	•	•	•	•	•	•
Counterbalanced and insulated double-skin door		•	•	•	•	•	•	•	•	•	•
Timed rinse		•					•				
Volumetric rinse			•					•			
Atmospheric boiler with break tank and rinse pump				•	•	•			•	•	•
Electronically-controlled drain pump			•		•	•		•		•	•
Stainless steel integral tank filter		•	•	•	•	•	•	•	•	•	•
Pump safety filter		•	•	•	•	•	•	•	•	•	•
Electronically controlled rinse-aid dosing unit		•	•	•	•	•	•	•	•	•	•
Electronically controlled detergent dosing unit		•	•	•	•	•	•	•	•	•	•

TECHNICAL DATA

Maximum real productivity*	racks/hour	35		35		40		40		
Maximum theoretical productivity	racks/hour	40		40		40		40		
Dimensions W x D x H	cm	46,5x55,6x69,5		46,5x55,6x69,5		60x60x72		60x60x72		
Door/hood opening	cm	32		32		28,5		28,5		
Tank capacity	lt	8		8		15		15		
Boiler capacity	lt	2,6		2,6		6		6		
Tank heating element	W	600		600		1.400		1.400		
Boiler heating element	W	2.600		2.600		4.900		4.900		
Wash pump - power	W	200		200		470		470		
Total power consumption	W	3.500		3.500		6.800		6.800		
Power supply voltage - Phases	V	230/50/1N		230/50/1N		400/50/3N		400/50/3N		
Max. current	amp	16		16		16		16		
Min-max water supply pressure	bar	2 - 4		1 - 4		2 - 4		1 - 4		
Min-max water supply temperature	°C	50 - 60		50 - 60		15 - 60		15 - 60		

* Water supply temp. 50°C, Rack loading and unloading time 12"

The IsyTech range

This product family is characterised by its double-skin construction, technical solutions and advanced functions, with operational flexibility ensured by three standard programmes and four special programmes organised into two direct access menus.

Construction

Full double-skin construction with stratified double-skin construction for the sides of the wash chamber. Full double-skin construction for the door. The tank has press-moulded bottom and is equipped with a full-width integral surface filter, which, thanks to its large intake size, is virtually unblockable. The wash chamber is free of internal pipes and sharp corners.

User interface

Easy to use, reliable and complete, with four soft touch keys and a 4-character LED display with two lateral indicator bars. Carefully chosen combinations of colours and graphic symbols provide a clear indication of the dishwasher status and wash cycle progress at a glance. In addition to the operating parameters, such as the temperature of the tank and boiler or

the number of cycles completed, the indications provided by the automatic diagnosis system are also displayed. The information is provided in the form of codes, text, or graphic indicators and colours.

It is possible to adjust the tank and boiler temperatures, the dosing of detergent and rinse aid, while our specialised technicians can modify all the operating parameters of the machine.

The versions

Versions with four different equipment levels are available, with and without water softener. The entire range and the various options can be seen in the table on the next page. All models are equipped as standard with electronically-controlled peristaltic dosing units for rinse aid.

Standard equipment

The glasswashers are equipped two flat rack, a cutlery container, approved filler hose and drain hose.



PROGRAMME SELECTION	33-10	33-10 D	33-10 SD	33-11 D	34-10	34-10 D	34-10 SD	34-11 D	34-12 D	34-13 D	35-10	35-10 D	35-10 SD	35-11 D
ProSpeed programme	•	•	•	•	•	•	•	•	•	•	•	•	•	•
ProFessional programme	•	•	•	•	•	•	•	•	•	•	•	•	•	•
ProTemp programme	•	•	•	•	•	•	•	•	•	•	•	•	•	•
ProWater programme	•	•	•	•	•	•	•	•	•	•	•	•	•	•
ProPlates programme	•	•	•	•	•	•	•	•	•	•	•	•	•	•
ProCold programme										•				
ProSelf self-clean programme	•	•	•		•	•	•		•		•	•	•	
ProClean self-clean programme and automatic drain				•				•		•				•
ProDrain automatic drain				•				•		•				•

TECHNOLOGIES		33-10	33-10 D	33-10 SD	33-11 D	34-10	34-10 D	34-10 SD	34-11 D	34-12 D	34-13 D	35-10	35-10 D	35-10 SD	35-11 D
DuoFlow pump						•	•	•	•	•	•	•	•	•	•
HiTech wash arms		•	•	•	•	•	•	•	•	•	•	•	•	•	•
UltraRinse rinse arm		•	•	•	•	•	•	•	•	•	•	•	•	•	•
QuickReady rapid tank heating system										•	•				
EnergySaving system		•	•	•	•	•	•	•	•	•	•	•	•	•	•
SmartClean construction		•	•	•	•	•	•	•	•	•	•	•	•	•	•
HotWash heating system		•	•	•	•	•	•	•	•	•	•	•	•	•	•
ThermoStop rinse control		•	•	•	•	•	•	•	•	•	•	•	•	•	•
SmartScreen user interface		•	•	•	•	•	•	•	•	•	•	•	•	•	•
ProRinse system										•	•				
ArchiMedes drain system		•	•	•		•	•	•		•		•	•	•	
EvoLution₃ drain system					•				•		•				•
ProGressive triple-stage filtration system					•				•		•				•
ProDose detergent control system			•	•	•		•	•	•	•	•		•	•	•
Manual water softener				•				•						•	

CHARACTERISTICS

Rack dimension	cm	35 x 35	35 x 35	35 x 35	35 x 35	39 x 39	39 x 39	39 x 39	39 x 39	39 x 39	39 x 39	45 x 45	45 x 45	45 x 45	45 x 45
Distance between guides	cm	35	35	35	35	38,5	38,5	38,5	38,5	38,5	38,5	45	45	45	45
Full stratified double-skin construction		•	•	•	•	•	•	•	•	•	•				
Deep-drawn rack guides		•	•	•	•	•	•	•	•	•	•				
Tank with press-moulded bottom		•	•	•	•	•	•	•	•	•	•	•	•	•	•
Double-skin door		•	•	•	•	•	•	•	•	•	•	•	•	•	•
Timed rinse		•	•	•		•	•	•				•	•	•	
Volumetric rinse					•				•						•
Atmospheric boiler with break tank and rinse pump										•	•				
Electronically-controlled drain pump					•				•	•	•				•
Integral tank filter in composite material		•	•	•	•	•	•	•	•	•	•	•	•	•	•
Pump safety filter		•	•	•	•	•	•	•	•	•	•	•	•	•	•
Electronically controlled rinse-aid dosing unit		•	•	•	•	•	•	•	•	•	•	•	•	•	•
Electronically controlled detergent dosing unit			•	•	•		•	•	•	•	•		•	•	•

TECHNICAL DATA

Maximum real productivity*	racks/hour		35				35				35				35		
Maximum theoretical productivity	racks/hour		40				40				40				40		
Dimensions W x D x H	cm		40,1x49x59,5				43,6x53,5x67				43,6x53,5x67				52,5x55,5x71,5		
Door/hood opening	cm		26				32				32				30		
Tank capacity	lt		7				8				8				14		
Boiler capacity	lt		2,6				2,6				2,6				2,6		
Tank heating element	W		600				600				600				600		
Boiler heating element	W		2.600				2.600				2.600				2.600		
Wash pump - power	W		150				200				200				200		
Total power consumption	W		3.500				3.500				3.500				3.500		
Power supply voltage - Phases	V		230/50/1N				230/50/1N				230/50/1N				230/50/1N		
Max. current	amp		16				16				16				16		
Min-max water supply pressure	bar		2 - 4				2 - 4				1 - 4				2 - 4		
Min-max water supply temperature	°C		50 - 60				50 - 60				50 - 60				50 - 60		

* Water supply temp. 50°C, Rack loading and unloading time 12"

The SteelTech range

This product family is characterised by its extreme simplicity of use, while still offering a wide choice of wash programmes and additional functions.

Construction

Full double-skin construction with partial double-skin construction for the sides of the wash chamber. Full double-skin construction for the door. The tank has press-moulded bottom and is equipped with a full-width integral surface filter, which, thanks to its large intake size, is virtually unblockable. The wash chamber is free of internal pipes and sharp corners.

User interface

Comprised of four sturdy function keys and a LED display which shows the wash and rinse temperatures. There are four wash programmes to choose from, including one specifically for glasses. The tank and boiler temperatures can be adjusted, as can the peristaltic dosing units for rinse aid and detergent (if present).

The versions

The entire range and the various options can be seen in the table on the next page.

Standard equipment

The glasswashers are equipped two flat rack, a cutlery container, approved filler hose and drain hose.



PROGRAMME SELECTION	33-00	33-00 S	33-00 D	33-01	33-01 D	34-00	34-00 S	34-00 D	34-01	34-01 D	35-00	35-00 S	35-00 D	35-01	35-01 D
ProSpeed programme	•	•	•	•	•	•	•	•	•	•	•	•	•	•	•
ProFessional programme	•	•	•	•	•	•	•	•	•	•	•	•	•	•	•
ProClean self-clean programme	•	•	•			•	•	•			•	•	•		
ProSelf & ProDrain programme				•	•				•	•				•	•

TECHNOLOGIES	33-00	33-00 S	33-00 D	33-01	33-01 D	34-00	34-00 S	34-00 D	34-01	34-01 D	35-00	35-00 S	35-00 D	35-01	35-01 D
DuoFlow pump						•	•			•	•	•	•	•	•
HiTech wash arms	•	•	•	•	•	•	•	•	•	•	•	•	•	•	•
UltraRinse rinse arm	•	•	•	•	•	•	•	•	•	•	•	•	•	•	•
EnergySaving system	•	•	•	•	•	•	•	•	•	•	•	•	•	•	•
SmartClean construction	•	•	•	•	•	•	•	•	•	•	•	•	•	•	•
HotWash heating system	•	•	•	•	•	•	•	•	•	•	•	•	•	•	•
ThermoStop rinse control	•	•	•	•	•	•	•	•	•	•	•	•	•	•	•
Mechanical user interface with thermometer	•	•	•	•	•	•	•	•	•	•	•	•	•	•	•
ArchiMedes drain system	•	•	•			•	•	•			•	•	•		
EvoLution₃ drain system				•	•				•	•				•	•
ProDose detergent control system			•		•			•		•			•		•
Manual water softener		•					•					•			

CHARACTERISTICS																	
Rack dimension	cm	35 x 35	35 x 35	35 x 35	35 x 35	35 x 35	39 x 39	39 x 39	39 x 39	39 x 39	39 x 39	39 x 39	45 x 45	45 x 45	45 x 45	45 x 45	45 x 45
Distance between guides	cm	35	35	35	35	35	38	38	38	38	38	38	45	45	45	45	45
Partial double-skin construction		•	•	•	•	•	•	•	•	•	•						
Deep-drawn rack guides		•	•	•	•	•	•	•	•	•	•						
Tank with press-moulded bottom		•	•	•	•	•	•	•	•	•	•	•	•	•	•	•	•
Double-skin door		•	•	•	•	•	•	•	•	•	•	•	•	•	•	•	•
Timed rinse		•	•	•			•	•	•			•	•	•			
Volumetric rinse					•	•				•	•					•	•
Electronically-controlled drain pump					•	•				•	•					•	•
Integral tank filter in composite material		•	•	•	•	•	•	•	•	•	•	•	•	•	•	•	•
Pump safety filter		•	•	•	•	•	•	•	•	•	•	•	•	•	•	•	•
Electronically controlled rinse-aid dosing unit		•	•	•	•	•	•	•	•	•	•	•	•	•	•	•	•
Electronically controlled detergent dosing unit				•	•			•		•			•		•		

TECHNICAL DATA																
Maximum real productivity*	racks/hour	35					35					35				
Maximum theoretical productivity	racks/hour	40					40					40				
Dimensions W x D x H	cm	40,1x49x59,5					43,6x53,5x67					52,5x55,5x71,5				
Door/hood opening	cm	26					32					30				
Tank capacity	lt	7					8					14				
Boiler capacity	lt	2,6					2,6					2,6				
Tank heating element	W	600					600					600				
Boiler heating element	W	2.600					2.600					2.600				
Wash pump - power	W	150					200					200				
Total power consumption	W	3.500					3.500					3.500				
Power supply voltage - Phases	V	230/50/1N					230/50/1N					230/50/1N				
Max. current	amp	16					16					16				
Min-max water supply pressure	bar	2 - 4					2 - 4					2 - 4				
Min-max water supply temperature	°C	50 - 60					50 - 60					50 - 60				

* Water supply temp. 50°C, Rack loading and unloading time 12"



ITW FOOD EQUIPMENT GROUP

EUROTEC s.r.l - divisione COLGED

Via Provinciale Romana, 6 - 55010 Badia Pozzeveri, LUCCA

Tel. +39 0583 2783 - Fax +39 0583 276506 - www.colged.eurotecgroup.com - info_colged@itweurotec.it



Non-binding technical data

Warning: The consumption and performance data indicated refer to machines installed and operating in ideal conditions and may vary according to installation conditions. The technical data furnished in this catalogue are for guidance purposes only and may be modified in accordance with the continuous technological development of our products.